

## ADVANTAGES

- Integrated, consecutive, three-unit design ideal for weighing, labelling and injecting baggage
- Provides an accurate, visual baggage weight display
- Ergonomic, low-profile design minimizes physical handling of baggage
- Automated baggage injection controls
- Smooth, quiet, efficient operation
- High quality stainless steel finish
- Knock-down rollers available to assist in baggage orientation

## OVERVIEW

The three-piece international style scale, labelling and queue conveyor combination is ideal for medium to high-density airports. The scale conveyor is designed to hold and accurately weigh baggage as it is checked-in. After advancing to the middle conveyor for labelling, baggage progresses to the queue conveyor to be automatically inserted onto the take-away conveyor when an opening is detected. This combination allows for greater accumulation of check-in baggage, while providing effective, efficient ticket counter capabilities.

Offered in standard widths, the modular design allows for conveyors to be manufactured in standard lengths, or customized to meet site-specific needs. All components are readily accessible for ease of regular maintenance and adjustments.

Finished to the highest of standards, and complimented with leading-edge components, this reliable design meets or exceeds all industry standards.



## GENERAL

- Simple, unique two-piece construction
- Formed 12 gauge steel construction

The scale-injection conveyor consists of both a *base frame* and a *conveyor module*.

The base frame is a rigid welded-assembly that houses the load cells and adjustable levellers, and is anchored in place at the ticket agent station.

The conveyor module, designed to be rolled in and out of position on the base, allows the unit to be removed for regular maintenance without being lifted.

The unit is complimented with a simple, yet effective, three roller design consisting of the *drive, tail, take-up / snub* rollers. These are all fully adjustable and accessible for quick and easy maintenance. The drive roller consists of a crowned, 5½" (140mm) diameter motorized pulley, complete with ¼" (6mm) lagging, while all other rollers are 2½" (64mm) diameter.

## TRIM / FINISHING

- 12 gauge stainless steel, #4 brush finish

Each conveyor is clad in easy to remove, low profile stainless that allows for belt adjustments and maintenance.

#### **CONVEYOR BELTING**

- Black, longitudinally ribbed, 2-ply woven polyester belting which is joined to form a continuous loop by means of a mechanical splice, or by vulcanization.

Other belting options are available as per page 2.3.3.

#### **MOTOR**

- Van Der Graaf motorized pulley, or equivalent

The unit is powered by a motorized pulley, selected for reliability, low-noise characteristics, and ease of maintenance. Capable of 30 cycles per minute, the motor is designed for the multiple starts associated with this application. An electrical disconnect, located beneath the conveyor, is used to facilitate quick and safe removal.

#### **DISPLAY PANELS**

- Optional one or two panel display

Electronic load cells, located beneath the scale conveyor base frame, accurately interpret and display the weight of the baggage in pounds or kilograms on one or two display panels provided with each unit.

Where two display panels are utilized, one is located for passenger view, while the other is mounted in the airline ticket operator console. Where one display is used, it is typically mounted visible to both parties.

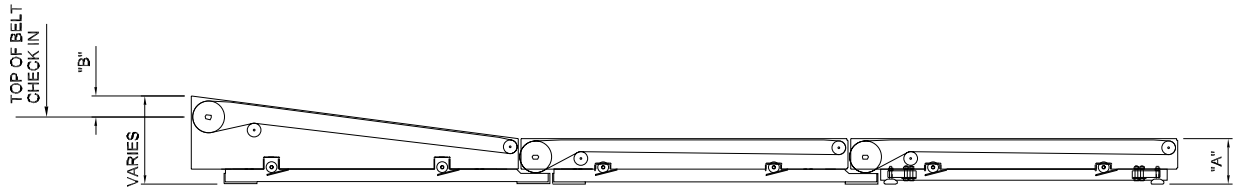

THREE PIECE SCALE CONVEYOR SPECIFICATIONS	
Description	G & S Standard
<b>Dimensions</b>	
Floor to Belt Surface ("A")	8 1/4" (210mm)
Cascade to Top of Belt Check-In ("B")	2 - 3 1/2" (51 - 81 mm)
<b>Specifications</b>	
Speed	120 ft/min (36.58 m/min)
Power per Unit	0.75 hp minimum
Ma. Bag Rate (bag/min)	18
Scale Capacity	200 lbs/ft (297.63 kgs/m)
Scale Graduation	0.22 lbs (0.1 kgs)
Scale Accuracy	±0.22 lbs (0.1 kgs)

Scale Make	
Standard	Optional
Atrax Group New Zealand	Division Systems
	Condec
	Other

Drive Options				
Application	Standard		Optional	
	Make	Model	Make	Model
Motorized Pulley	Van Der Graaf		BDL	DuraDrive
			Interroll	

Belting Options				
Application	Standard		Optional	
	Make	Model	Make	Model
General Purpose	Nitta	BLRB-16A	Ammeraal Beltech	EX 10/2 0+A32 Black AS FR
			Habasit	NSL-11ESBV
			Siegling America	E8/2 U0/V15 LG-FR
Specialized	Nitta		Ammeraal Flexam	EX 8/2 0+A20 Black AS FR
			Habasit	NAD-10ESBV

**THREE-PIECE INTERNATIONAL STYLE CONVEYOR**

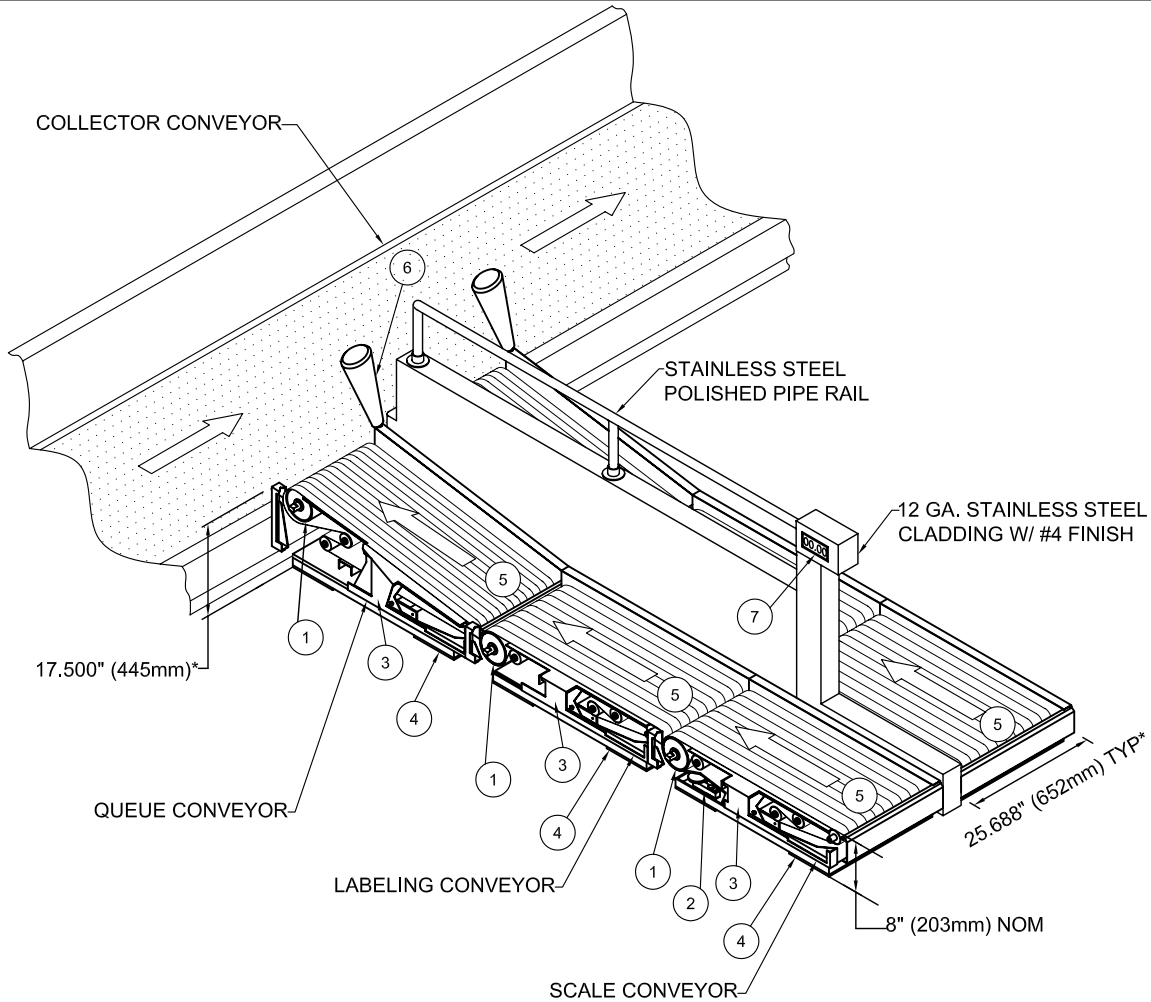

ITEM	COMPONENT
1	Motorized Pulley
2	Load Cell
3	Stainless Steel Side Cover (Shown Partially Removed For Clarity)
4	Base Frame
5	Conveyor Belt
6	Knock-down Roller
7	Scale Display

\*TO CUSTOMER'S REQUIREMENTS

**NOTES:**

1. The Scale Conveyor Consists of Two Separate Pieces: (1) The Actual Conveyor and (2) The Scale Section. There are Wheels Connected to The Conveyor. When and If Maintenance is Required, the Conveyor can be Rolled Off the Scale on These Wheels.
2. Scale Resolution 0-200 LBS (0-91 KGS) In 1LB (0.45 KG) Increments.