

ADVANTAGES:

- **High Density, Sloping-Face Make-up or Claim Conveyor**
- **90 FPM, Clockwise or Counter-clockwise operation**
- **Modular design allows flexibility and versatility of system design**

OVERVIEW:

The slope plate conveyor is a high capacity, sloping-face, baggage conveyor which features a number of overlapping flites that are linked together, providing an endless, re-circulating conveyor surface. This unit is suitable for baggage claim and / or baggage make-up functions in high-density airports.

Normally operating at a speed of 90 feet per minute, the slope plate is capable of travelling in either a clockwise or counter-clockwise direction. Loading of the unit can be achieved by feeding baggage from above or below the center of the device at any point along the upper perimeter of the conveying surface.

Manufactured with durable materials, finished to the highest standards, and complimented with leading-edge mechanical and electrical components, this robust and reliable design meets or exceeds all industry standards.



CONVEYING SURFACE

- 63" (1600mm) Conveying width
- 22.5° Sloped surface
- Polyurethane arresting buffers
- Heavy duty support wheels

The conveying surface is comprised of individual rectangular, overlapping flites, angled 22.5° from horizontal, that are supported by structural splines and load bearing wheels, which are directly coupled to the main conveyor chain.

Flites are mechanically fastened to formed steel splines to provide the necessary structural support. The lower end of each flite is fitted with polyurethane buffers to cushion baggage as it is discharged, and slides down from the feed conveyor. The entire flite and spline assembly forms an integral link in the main conveying chain, which is positively engaged by the drive chain. A restraint strap, fixed between the articulating ends of each spline, ensures that the correct pitch distance is maintained between flites.

Each flite and spline assembly is supported by an upper and a lower heavy-duty support wheel. The support wheels are comprised of a high-density plastic tire molded onto a precision, sealed-for-life ball bearing.

FLITES

- 14 gauge stainless steel (type 304, #4 finish) complete with leading edge, underside wear strip -or-
- ¼" (6mm) textured ABS plastic

The quality-controlled flites meet and exceed the dynamic and static loads specified for slope plate conveyors and will support a live load weight of 250 pounds (114.40kgs), experiencing no undue deflection or damage.

The overall flite-assembly design results in superior strength and flexibility while providing the wear and abrasion resistance properties necessary to withstand both known and anticipated wear and tear in modern airport terminals.

FRAMEWORK

- Modular design
- Robust, fully-supported frame structure

A modular approach to the framework allows the slope plate conveyor to be manufactured, shipped, and assembled efficiently and economically.

A-frame cross-section supports are constructed using formed steel components and welded in quality-controlled fixtures. These frames form the rigid, grid-like support structure to which the guide rails, bearing tracks, and cross-bracing members are bolted, and later welded to, making a continuous, fully supported frame structure. The entire unit is mounted above the floor, supported and levelled on robust screw adjustable legs.

All components of the framework structure are treated with a protective, rust-inhibiting finish.

CONVEYOR TRIM / FINISHING

- Top of outer trim: 18" (457mm) minimum above floor level
- 12 gauge stainless steel, type 304, #4 brush finish

Slope plate conveyors operating in public areas for baggage claim functions are finished with 12 gauge stainless steel, while slope plates operating for baggage make-up are finished in galvanized mild steel.

Slope plate conveyors, intended for baggage claim functions, typically require the open center area to be enclosed and finished. This is accomplished by installing fire-rated, plywood decking material level with the top of the inner up-stand panelling, supported by a metal framework, and finished with decorative covering. An access hatch is provided over the motor / gearbox unit to allow for maintenance.

An optional, protective bumper rail can be provided around the circumference of the unit to deflect any potential damage from baggage carts and tugs.

DRIVE

- Caterpillar drive system

The slope plate conveyor drive module incorporates the proven caterpillar drive principal. Operating in a horizontal, triangular configuration, the endless, precision transmission chain, complete with drive-lugs connected at regular intervals, engage the main conveying chain, moving the conveyor along its path. No less than two flite assemblies are positively engaged at any time, resulting in a direct mechanical link between the drive chain and the conveying surface.

MOTOR / REDUCER

- SEW Eurodrive constant speed gear motors, or equivalent
- Variable Frequency Drive

Powered by a direct drive motor / gearbox, assembly selected for reliability, low noise characteristics and ease of maintenance, the unit is complimented by a variable frequency drive (VFD). This combination provides the speed reduction required and an electronic soft start / stop function, allowing for smooth acceleration and deceleration, with minimal shock loading.

As an added benefit, the unit can be adjusted down to 1-2 fpm (0.005-0.010 mps) for inspection and maintenance.

The gear motor and wall mounted control cabinet are typically located on the non-public side of operations to accommodate regular access and maintenance.

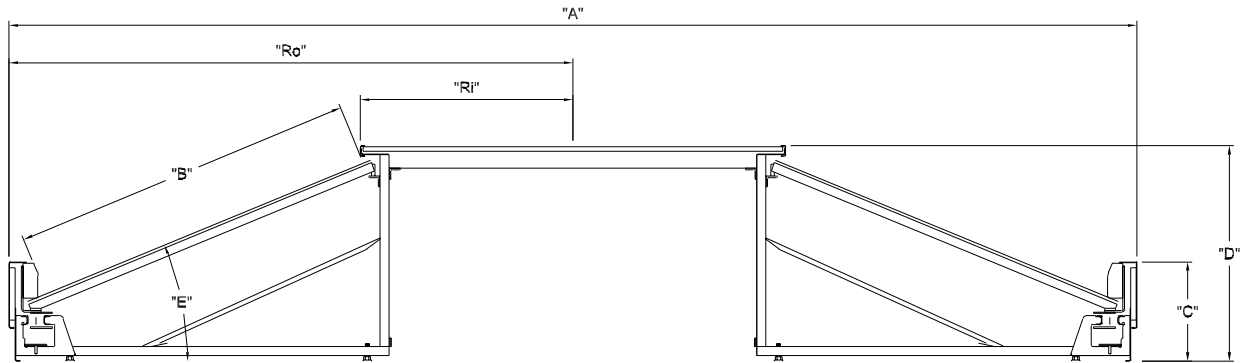

SLOPE PLATE CONVEYOR SPECIFICATIONS	
Description	G&S Standards
Dimensions	
Overall Width ("A")	17'-0 $\frac{1}{8}$ " (5185mm) minimum
Conveying Width ("B")	63" (1600mm)
Floor to Outer Trim Height ("C")	18" (457mm) minimum
Floor to Inner Trim Height ("D")	39 $\frac{3}{8}$ " (975mm) minimum
Flite Angle/Pitch ("E")	22.5°
Inner Radius ("Ri")	38 $\frac{1}{2}$ " (978mm)
Outer Radius ("Ro")	102" (2591mm)
Standard Module Length	9'-10 $\frac{1}{8}$ " (3000mm)
Specifications	
Speed	90 ft/min (27.43 m/min)
Conveying Surface (Public)	12 ga Stainless Steel
Conveying Surface (Air Side)	Black ABS

Materials & Finish		
Application	Public View	Non-Public View
Trim / Finish	12 ga Stainless Steel, Type 304, #4 Brush	12 ga Galvanized Mild Steel

Drive Options				
Application	Standard		Optional	
	Make	Model	Make	Model
90 Deg. Reducer	SEW Eurodrive	SA - Hollow Shaft ST - TorqLOC	Dodge	Ti-Gear